



type 656

Mini hour counters, 4,5 - 35 V DC, 32 x 15 mm

Mini hour counter for 4,5 to 35 V DC

These mini hour counters for DC operation are suited for panel or printed circuit mounting. Find the corresponding pulse counters with same dimensions on page 42.

DC	front panel mounting (snap-in fixing max. 3 mm)
----	---

656	■
-----	---

Special features:

- with disable input for recording very short operating times
- high shock- and vibration resistance
- little current consumption
- well suited for battery-operated application and electronic circuits

Technical specifications:

	DC
reset:	no
counting range:	99999,99 h
character height:	4 mm
operating voltage:	4,5 to 35 V DC
power consumption:	at $U_B = 5$ V DC type 82 mW at $U_B = 12$ V DC type 135 mW at $U_B = 24$ V DC type 135 mW max. 170 mW Only every 36 s with a pulse length of 3 ms
protection:	IP 65 (front)
ambient temperature:	- 10° C to + 60° C
electr. connections:	soldered conn. 0,4 x 1,2 mm
weight:	16 g
maintenance-free operation:	yes

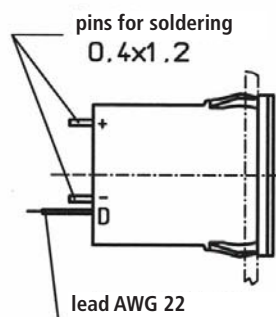
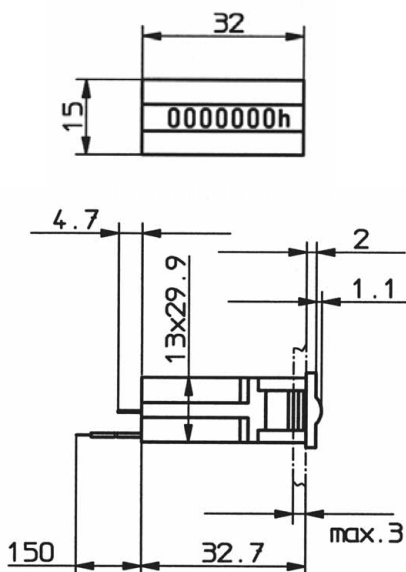

drawings

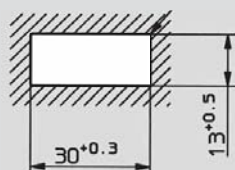

cutout

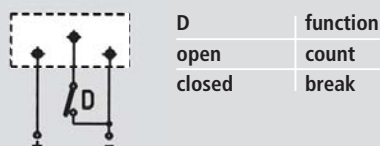

wiring diagram