



ENCODER ROTATIVI INCREMENTALI

INCREMENTAL ROTARY ENCODERS



Encoder rotativi incrementali monodirezionali (SE) e bidirezionali con o senza impulso di zero (SEB/SEB-Z). Affidabili, precisi con caratteristiche meccaniche tali da consentirne l'impiego anche nelle condizioni più gravose. 

Incremental rotary encoders, monodirectional (SE) or bidirectional (SEB), with (SEB-Z) or without zero pulse. Accurate and reliable, their stout mechanical features make them fit to applications even in very harsh conditions. 



CARATTERISTICHE MECCANICHE ED AMBIENTALI MECHANICAL AND ENVIRONMENTAL SPECIFICATIONS





• Dimensioni / Dimensions	Vedi disegno / See the drawing
• Peso / Weight	400 g
• Materiali: Custodia Albero Materials: Case Shaft	ABS autoestinguente Acciaio inox AISI 303 ABS self-extinguishing Stainless steel AISI 303
• Diametro albero / Shaft diameter	10 mm
• Giri-minuto	6000* continuo - 10000 temporaneo * velocità massima di funzionamento con anello di tenuta IP65 applicato sull'albero: 3000 giri/min
• Revolutions per minute	6000 continuous* - 10000 temporary * Max operating speed with IP65 sealing ring applied on the shaft: 3000 rpm
• Coppia di avviamento / Starting torque	0.8 Ncm
• Momento di inerzia / Inertia	25 g cm ²
• Carico ammesso / Max load	80 N assiale - 100N radiale / 80 N axial - 100 N radial
• Resistenza alle vibrazioni (10÷2000 Hz) Resistance to vibrations (10÷2000 Hz)	100 m/sec ²
• Resistenza all'urto (11 ms) Shock resistance (11 ms)	50 G
• Grado di protezione / Protection degree	IP64 (optional IP65)
• Temperatura di esercizio Operating temperature	0 ÷ +60°C
• Temperatura di immagazzinamento Stocking temperature	-20 ÷ 80°C
• Accessori di montaggio Mounting fittings	Braccio supporto in fusione di alluminio Ruote misuratrici a sviluppo noto (200 o 500 mm) Supporting arm of casting aluminium Measuring wheels development 200 or 500 mm

CARATTERISTICHE ELETTRICHE E FUNZIONALI ELECTRICAL AND OPERATING SPECIFICATIONS

• Codice impulsi / Pulse code	Incrementale / Incremental
• Segnali di uscita	SE: Onda quadra SEB/SEB-Z Due onde quadre sfasate di 90°±15° Impulso di zero larghezza 90° ± 15°
• Output Signal	SE: Square wave SEB/SEB-Z Two square waves 90°±15° out of phase Zero pulse 90° ± 15° wide
• Elettronica di uscita	Push-pull, open collector NPN, pull-up resistor NPN, line driver Segnali protetti al corto circuito
• Electronic output	Push-pull, open collector NPN, pull-up resistor NPN, line driver Signals protection against short circuits
• Alimentazione	10÷24 Vdc o 5 Vdc±5%
• Supply	Protezione contro le inversioni di polarità 10÷24 Vdc or 5 Vdc±5% protected against polarity reversal
• Assorbimento	30÷80 mA
• Tipi di connessione	Cavo assiale lunghezza 3 m, (1 m per uscita line driver) Optional: connettore assiale tipo MS
• Connection outlets	Axial cable 3 m long, (1 m for line driver output) Optional: axial connector type MS
• Numero impulsi-giro	2÷1024
• Pulses-revolution	
• Impulso di zero	SEB-Z Un impulso al giro
• Zero reference pulse	SEB-Z 1 pulse each revolution
• Frequenza max	100 KHz
• Max frequency	

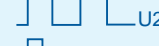
ELETRONICA - ELECTRONICS

• Open collector - pull-up resistor - push-pull	
	U1
	U2
	Uz
	Tensione alimentazione Supply
	10 ÷ 24 Vdc 5 Vdc ± 5%

• Line driver	
	U1
	U2
	Uz
	$\bar{U}1$
	$\bar{U}2$
	$\bar{U}z$
	Tensione alimentazione Supply
	10 ÷ 24 Vdc 5 Vdc ± 5%

Con schema collegamenti 3-4-5 (solo SEB/SEB-Z). segnale 2 in ritardo rispetto al segnale 1 con rotazione in senso antiorario (vista dall'albero).
With connection diagram 3-4-5 (type SEB/SEB-Z only): signal 2 lags signal 1 with anticlockwise rotation (seen from the shaft side).

COLLEGAMENTI - CONNECTIONS

• Open collector - pull-up resistor - push-pull

SCHEMA 5

A = Segnale 2*
 B = 0 Volt
 C = Segnale Z (solo per SEB-Z)
 D = + Vcc
 E = Segnale 1
 * solo su bidirezionale

SCHEMA 5

A = Signal 2*
 B = 0 Volt
 C = Signal Z (for types SEB-Z only)
 D = + Vdc
 E = Signal 1
 * for bidirectional types only

CAVO

Verde = Segnale 2*
 Bianco = Segnale 1
 Blu = 0 Volt
 CALZA = Schermo
 Rosso = + Vcc
 Marrone = Segnale Z (solo per SEB-Z)
 * solo su bidirezionale

CABLE OUTLET

Green = Signal 2*
 White = Signal 1
 Blue = 0 Volt
 Braid = Shield
 Red = + Vdc
 Brown = Signal Z (for types SEB-Z only)
 * for bidirectional types only

• Line - driver

SCHEMA 3 (senza impulso di zero)

A = Segnale 1
 B = Segnale 2
 C = Segnale 1
 D = + Vdc
 E = Segnale 2
 F = 0 V
 G = Non collegato

SCHEMA 3 (without zero pulse)

A = Signal 1
 B = Signal 2
 C = Signal 1
 D = + Vdc
 E = Signal 2
 F = 0 V
 E = Non connected

SCHEMA 4 (con impulso di zero)

A = Segnale 1
 B = Segnale 2
 C = Segnale Z
 D = + Vdc
 E = + Vdc
 F = 0 V
 G = Segnale 1
 H = Segnale 2
 I = Segnale 2
 J = Non collegato

SCHEMA 4 (with zero pulse)

A = Signal 1
 B = Signal 2
 C = Signal Z
 D = + Vdc
 E = + Vdc
 F = 0 V
 G = Signal 1
 H = Signal 2
 I = Signal 2
 J = Non connected

COME ORDINARE / ORDERING INFORMATION

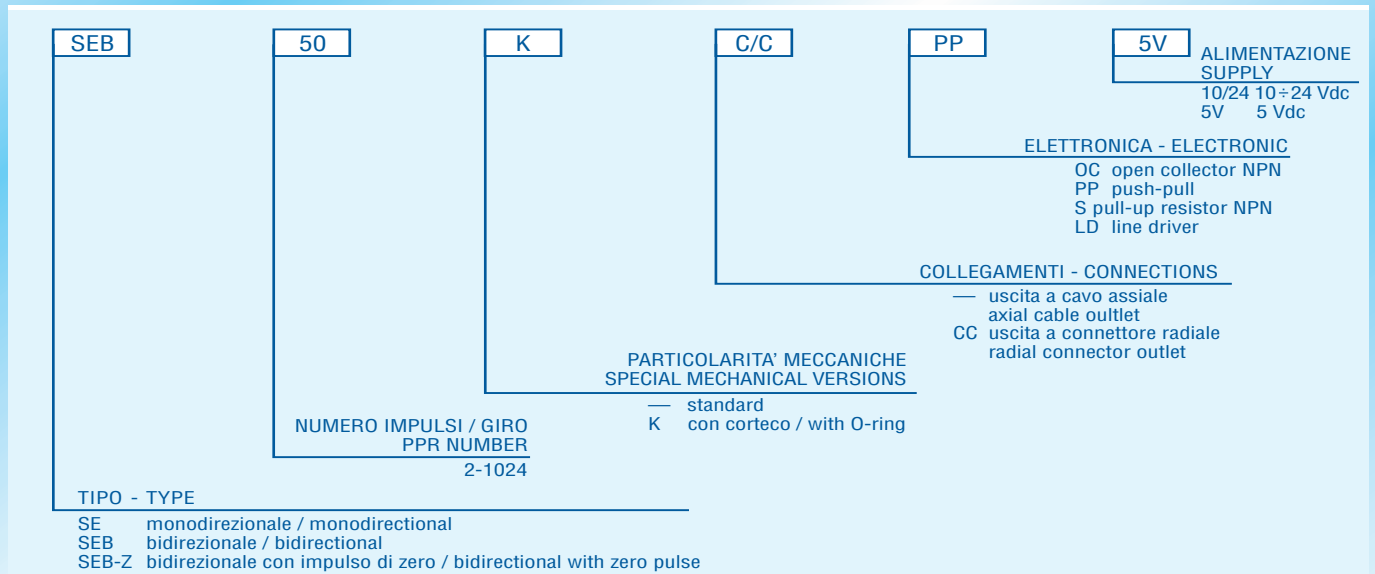

ACCESSORI / ACCESSORIES

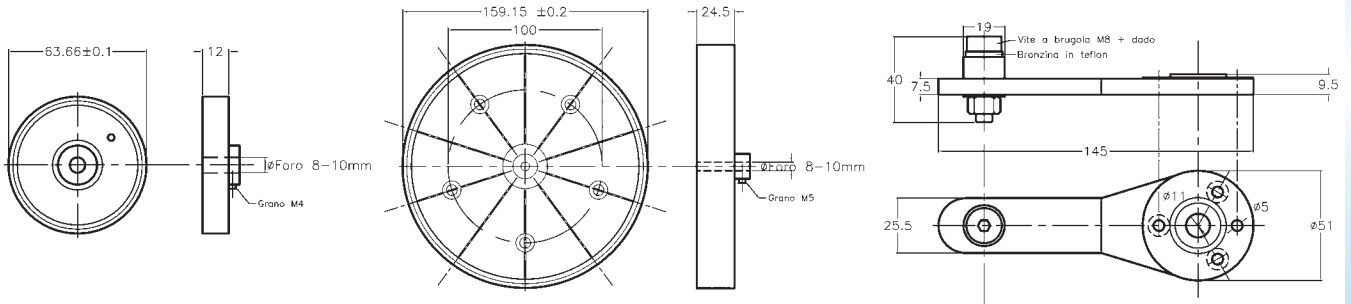

DIMENSIONI D'INGOMBRO / DIMENSIONS

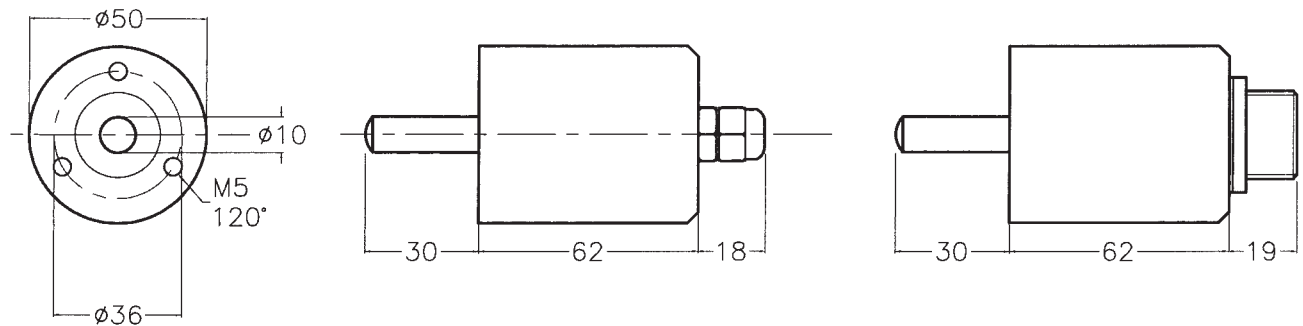

CON RISERVA DI VARIAZIONE VARIATIONS ADMITTED WITHOUT NOTICE