



Subject to change without notice!
Rev. 0701

Flat sensor MESEP®

SP

Application

These flat sensors are detectors for all types of metal for the use in conveyor belts and chutes. Using them it is possible to inspect bulk material as well as finished goods. Foils or other roll goods can be led directly over the sensor and thus be detected on metallic contamination. The sensors serve for quality assurance as well as for machine protection. Beyond that the flat detectors are also appropriate for applications of the process control e.g. for object counting or for completeness checks. In combination with the optionally available control unit conveyor plants and discharging units can be controlled directly.

Function & handling

The sensor has a dynamic working principle which means it only detects moving metallic pieces in the sensor range. If a non-moving metal piece is situated in the detection range, it does not excite a signal and therefore is not detected. Contrary to sensors with a static working principle this system allows operation with a much higher sensitivity. Thus even small metallic pieces can be detected dead reliable. The operation of the sensor requires a control unit. This realises the voltage supply for the sensors and allows the adjustment of all parameters. The detailed functioning and handling depends on the control unit.



Flat sensor MESEP® SP

Specific characteristics

- different sensor widths available (150 mm - 1200 mm)
- no metal-free zones necessary
- stable and shock proofed aluminium housing
- easy mounting
- separate control electronics with freely adjustable functions
- protection class IP67
- sensitivity adjustable via control electronics



Type	MESEP® SP 150 - 1200		
Mechanical data			
Dimension	L x W x H: Length x 210 x 60,5 mm		
Length	150 mm - 1.200 mm (available in steps of 50 mm) ²		
Housing	aluminium - strand profil		
Active surface	polyurethane		
Electrical data			
Supply voltage	15 VDC		
Output	analog voltage output		
Electrical connection	PVC - cable; 2 m		
Conditions of use			
Storage temperature	-10°C .. 70°C		
Operating temperature	-10°C .. 60°C		
Protection class	IP67		
Speed ¹	1 - 120 m/min		
Order information			
	Order number	Length ²	
MESEP® SP 150	08317696900	150 mm	
MESEP® SP 200	08317697124	200 mm	
MESEP® SP 250	08317697240	250 mm	
MESEP® SP 300	08317697341	300 mm	
MESEP® SP 350	08410697442	350 mm	
MESEP® SP 400	08317697601	400 mm	
MESEP® SP 450	08317697702	450 mm	
MESEP® SP 500	08317697803	500 mm	
MESEP® SP 550	08317697912	550 mm	
MESEP® SP 600	08410698020	600 mm	
MESEP® SP 650	08317698114	650 mm	
MESEP® SP 700	08317698164	700 mm	
MESEP® SP 750	08410698264	750 mm	
MESEP® SP 800	08317698296	800 mm	
MESEP® SP 850	08317698348	850 mm	
MESEP® SP xxx	auf Anfrage	> 850 mm	
Control unit (10 fold)	standard	for top hat rail	with reverting conductor
	08349005000	08349005001	08349005002
Control unit (1 fold)	230VAC/24VDC → 08349005010		115VAC/24VDC → 08349005012



Type	MESEP® SP 150 - 1200
Sensitivity	
	Maximum distance between sensor and test piece.
Fe-plate 30 x 30 x 1mm	95 mm
Fe-plate 12 x 12 x 1mm	68 mm
Nut M6	56 mm
Fe-ball Ø 7,0mm	44 mm
Nut M4	44 mm
Washer M4	37 mm
Washer M3	33 mm
Nut M2,5	33 mm
Fe-ball Ø 4,5mm	30 mm
Fe-ball Ø 3,0mm	20 mm
Fe-ball Ø 2,5mm	14 mm
Fe-ball Ø 2,0mm	8 mm

Instructions for operation with control unit

Depending on the size of the sensor it has a certain number of analog outputs. Each output has to be operated using a control unit. Additionally it is possible to use several single control units or one multi control unit.

Sensor width [mm]	Analog outputs
150 - 250	2
251 - 450	3
451 - 650	4
651 - 800	5
801 - 901	6
901 - 1000	7
1001 - 1200	8

¹ Other lengths and in-between sizes on request.

² Higher stream velocities can allow the sensitivity.

Dimensions MESEP® SP 150 - 350

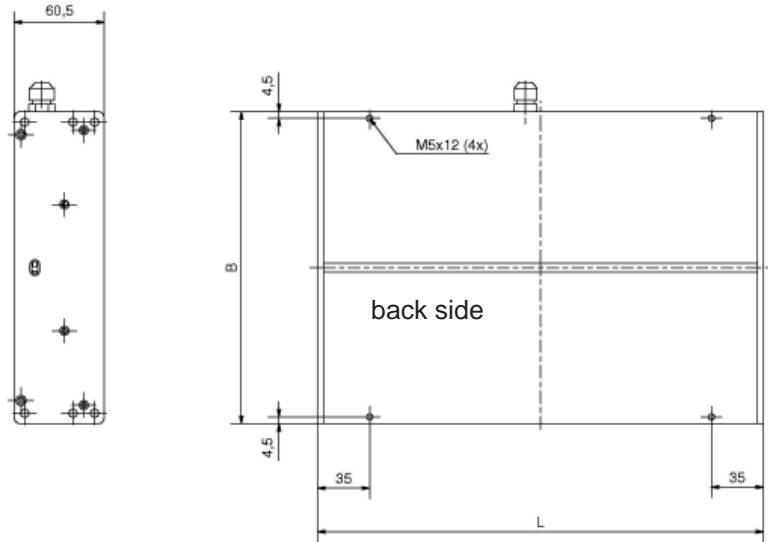

Dimensions MESEP® SP 350 - SP 1200

