



Subject to change without notice!
Rev. 0701

Metal separator

M-Pulse / Digital+ / Digital / MESEP

SE

Application

This type of separators is used for various applications in the plastics and the chemical industry. All important components of the SE are made of stable die-cast aluminium. Due to this the separator is indestructible and guarantees durability and longevity even under adverse conditions.



Metal separator SE

Function

In the upper part of the separator the sensor coil of the metal detector is situated. If metal falls through the sensor the signal is collected and processed by the operating electronics. Subsequently the electronics precisely excites the pulse for piloting the ejection flap. The flap is opened and metal is separated safely from the product stream. The robust, pneumatic driven mechanics guarantees durability. The function of the mechanics can be monitored constantly by several alerter. Thus the device constantly ensures that all metallic pieces have really been separated from the product stream.

Specific characteristics

- maintenance-free mechanics
- different transmission ports available
- robust, pneumatic-driven ejection mechanics
- large range of accessories available
- all devices are mechanically compatible
- compact design



Type	SE 35		SE 50		SE 70		SE 100	
Mechanical data								
Height	365,5 mm (400 mm with flange)							
Sensor aperture - D model MESEP SE	29 mm		45 mm		65 mm		94 mm	
Sensor aperture - D model Digital+ SE model M-Pulse SE	29 mm		45 mm		65 mm		not available	
Sensor aperture - D model Digital+ SE	not available		45 mm		65 mm		not available	
Material-ejection flap	stainless steel							
Material-base frame	cast aluminium / stainless steel							
Material-protection tube ²	phenolic resin							
Payload	max. 150 kg							
Weight	~ 21 kg							
Conditions of use								
Storage temperature	-10 .. 60°C							
Operating temperature	0 .. 60°C							
Protection class	IP50							
Electrical connection	see datasheet of the control units							
Pneumatic connection	4-6 bar, filtered, free of water and oil; self-sealing-coupling - fitting NW 7,2							
max. drop height of the bulk material	0 .. 600 mm (from top edge)							
Troughput ³	600 l/h		2.000 l/h		5.400 l/h		14.000 l/h	
Sensitivity¹								
Material - test pieces	FE	SS	FE	SS	FE	SS	FE	SS
M-Pulse	0,2	0,5	0,3	0,9	0,4	0,9	not available	
Digital+	0,3	0,6	0,35	1,1	0,5	1,2	not available	
Digital	not available		0,5	1,5	0,7	2,0	not available	
MESEP	0,5		0,6		1,0		1,3	

Order code:

Electronic

M-Pulse / Digital+ / Digital

Type of separator

SE 35 - SE 100

(e.g.: Digital+ SE 70)

¹ The actual sensitivity depends on various factors. Unfavourable environmental conditions or vibrations can reduce the sensibility. Conductive test material can also influence the sensibility. For obliging information please contact our service or sales department. Our service includes product tests in our headquarters. (all data in mm)

² Other materials available. (glas, antistatic; wear-resistant)

³ Measured with granulate PET - grain dimension 2 - 4 mm.



Special design & accessories

Designation	Order number
Voltage- und pneumatic guard (Flap automatic switches into throw-off position at blackout or falling pressure)	When ordering please add option 40.
Wear-resistant model (for very abrasive bulk material)	When ordering please add option 44.
Test pieces - certified - Fe/NonFe/SS (several diameters)	on request

Application example



MESEP SE 50 for the inspection of granulates in the plastics industry.

Metal separator SE

Dimensions

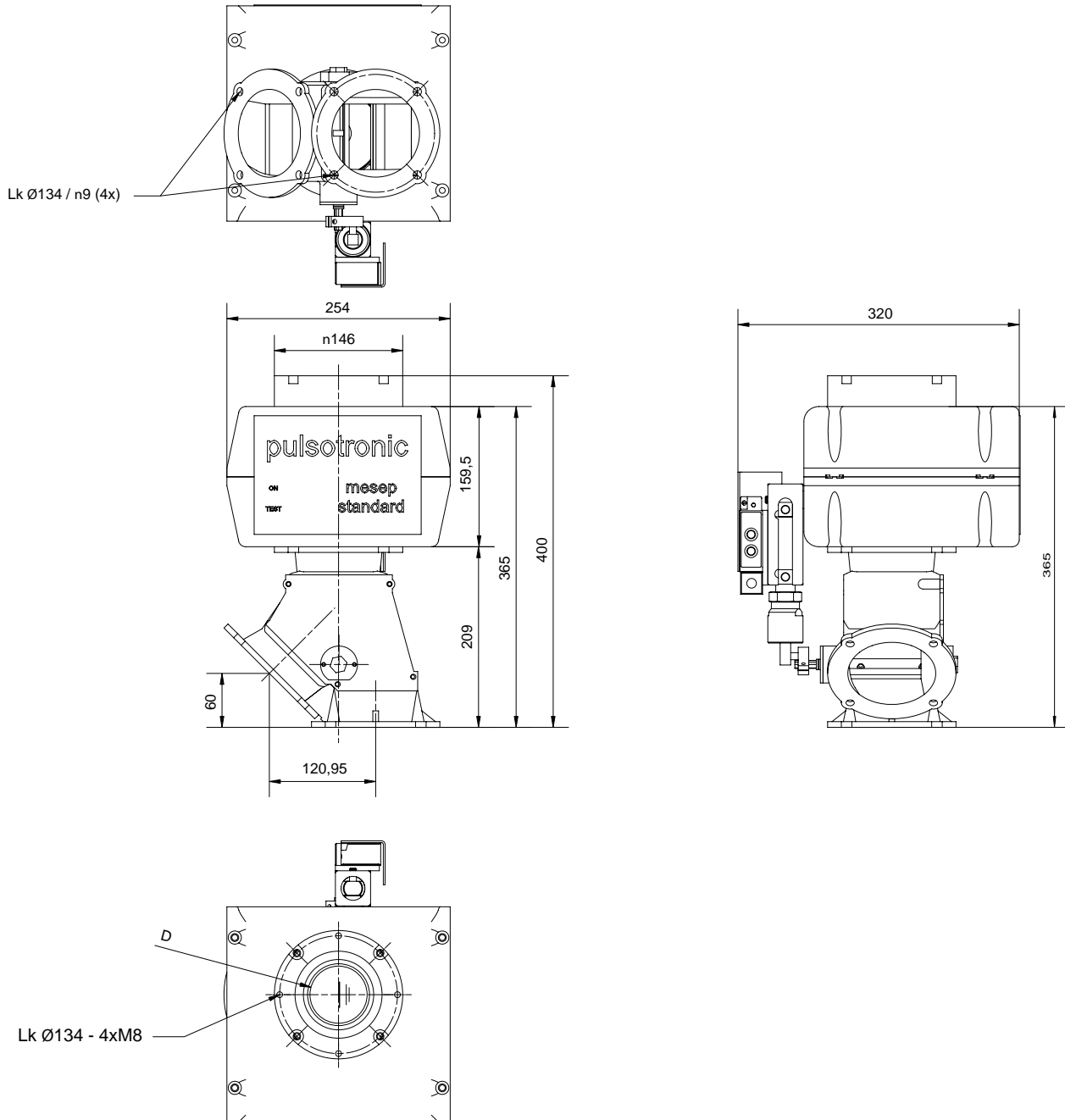

Devices with the operating electronics M-PULSE, Digital oer Digital+ request an external control electronics which is connected via a 3 m connecting cable with the separator. The dimensions of the electronics are given in the particular data sheets.