

## Signal Conditioners for Position Transducers LWH and TLH

Series MUW 200



### Special features

- Interface module for series TLH and LWH position transducers
- Sensor proximity in the plug connection
- Interference-free signal transmission
- standardized output signals  
0... 10 V  
± 10 V  
0... 20 mA  
4... 20 mA
- excellent linearity
- extremely low temperature drift 30 ppm/K (typical value)
- Zero point and range optionally adjustable or fixed

The signal conditioner supplies the position transducers with a highly stable constant voltage.

The wiper signal is picked off without load via a high-resistance input stage and transformed into a displacement-proportional standardized output signal.

The excellent linearity, low temperature drift and sensor-proximity of the signal-conditioning process ensure full utilization of the outstanding benefits of the position transducers, guaranteeing the reliable, interference-free transmission of signals even over long distances.

In the adjustable models, the zero point and range can be adjusted within wide limits using spindle trimmers. This permits standardized output signals to be adjusted even if the maximum path of the transducer is not completely utilized.

The electronic circuitry is integrated into a socket to fit the DIN 43650 appliance plug. The wide operating voltage range permits to be supplied by unstabilized direct voltage sources. Selected SMD components with a wide temperature range guarantee maximum operating reliability even under extreme environmental conditions.

The MUW is connected by means of a four-pole terminal strip. It is possible to orient the connecting cable as required by turning the housing insert in 90° steps.

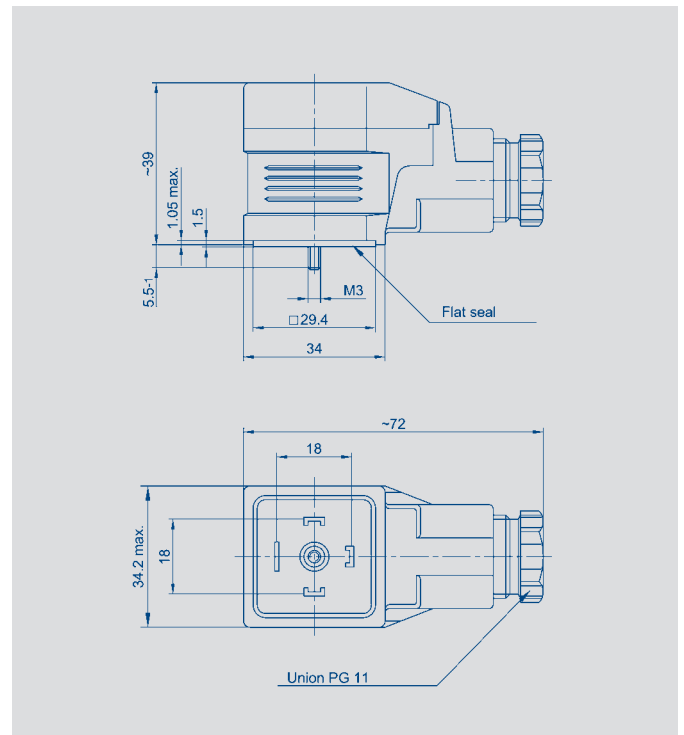

### Mechanical data

Dimensions	see drawing	
Protection class	IP 65 (DIN 400 50 / IEC 529)	
Screw-type terminals	0.5	mm <sup>2</sup>
Recommended cable dia. 4 - 10 mm	3 or 4 core twisted with protective braiding	
Weight	appr. 75	g
<b>Electrical data</b>		
Operating voltage	18 ... 30	VDC
Input resistance	>10	MΩ
Reverse voltage protection	integrated	
Current consumption	max. 35	mA
Internal reference voltage for the position transducer, highly stable and short circuit-proof	>10	V DC
Permissible connection resistance of the position transducer	≥700	Ω
Adjustment range		
Zero point	10	%
Gain	1...2	
Linearity	0.01 (typical)	%
Temperature coefficient*	30 (typical)	ppm/K
Temperature range	-25...+70	°C

\*The TC applies for current and voltage outputs. If, at current outputs, the voltage is picked off at the load resistor, the TC of the resistor must also be taken into consideration.

## Connection diagram

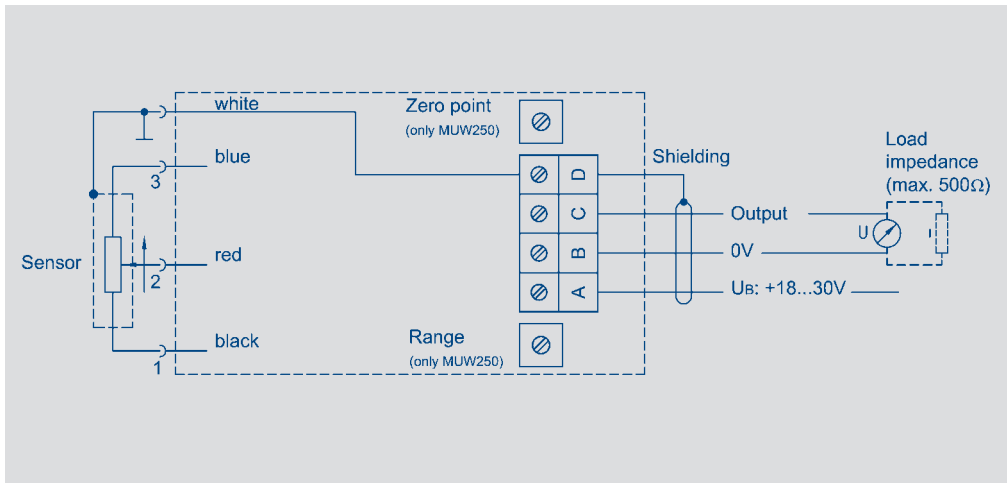

The output signal rises when the actuating rod (LWH) or the actuator (TLH) of the position transducer is moved from 1 to 3 (status on delivery). If the reverse action is required, the terminals 1 (black) and 3 (blue) must be exchanged at the socket insert. After removing the transparent lid, the socket insert can be pushed outwards.

## Order designations

Series	Type	Output	Art.no.
M U W	Series 200 range and zero point not adjustable	0 = 0 ... 20 mA (Load impedance max. 500 Ω)	054101
		1 = 0 ... 10 V (I max. 20 mA short circuit-proof)	054102
	Series 250 range and zero point adjustable	4 = 4 ... 20 mA (max. load impedance 500 Ω)	054103
		0 = 0 ... 20 mA (Load impedance max. 500 Ω)	054151
		1 = 0 ... 10 V (I max. 20 mA short circuit-proof)	054152
		4 = 4 ... 20 mA (max. load impedance 500 Ω)	054153
		6 = ±10 V (I max. 20 mA short circuit-proof)	054154

**Special configurations with different supply voltages, voltage outputs or setting ranges on request.**

**Included in delivery**  
 1 M3x40 central screw  
 1 flat seal